

# ART. D454

## “EUROMODEL” FOUR ARM CONTROL HANDWHEEL

**MATERIAL:**

Special high resistance glass fibre reinforced technopolymer.  
Oils and greases resistant.

**SURFACE:**

Satin.

**HANDWHEEL COLOUR:**

Black (RAL 9011).

**CENTRAL CAP:**

Grey polyamide (RAL 7035 code 13).

**ALTERNATIVE CAP COLOUR:**

Orange (RAL 2004 code 02).  
Blue (RAL 5015 code 07).  
Yellow (RAL 1021 code 10).  
Red (RAL 3000 code 16).  
Green (RAL 6024 code 17).  
Black (RAL 9011 code 01).

**MAIN INSERT:**

Zinc plated steel right through bored bush with H7 tolerance.

**HUB:**

Hollow underneath hub.

For fixing systems, or execution of tabs or square holes, please refer to the technical notes attached to the catalogue.

**SPECIAL REQUESTS:**

- It is possible to supply the inserts with d1 diameter by customer design, on request and for quantities.
- It is possible to supply the inserts with threaded d1 diameter, on request and for quantities.
- It is possible to supply the inserts in different materials, on request and for quantities.
- It is possible to supply the inserts with different treatment-finishes, on request and for quantities.

**PROTECTED MODEL**

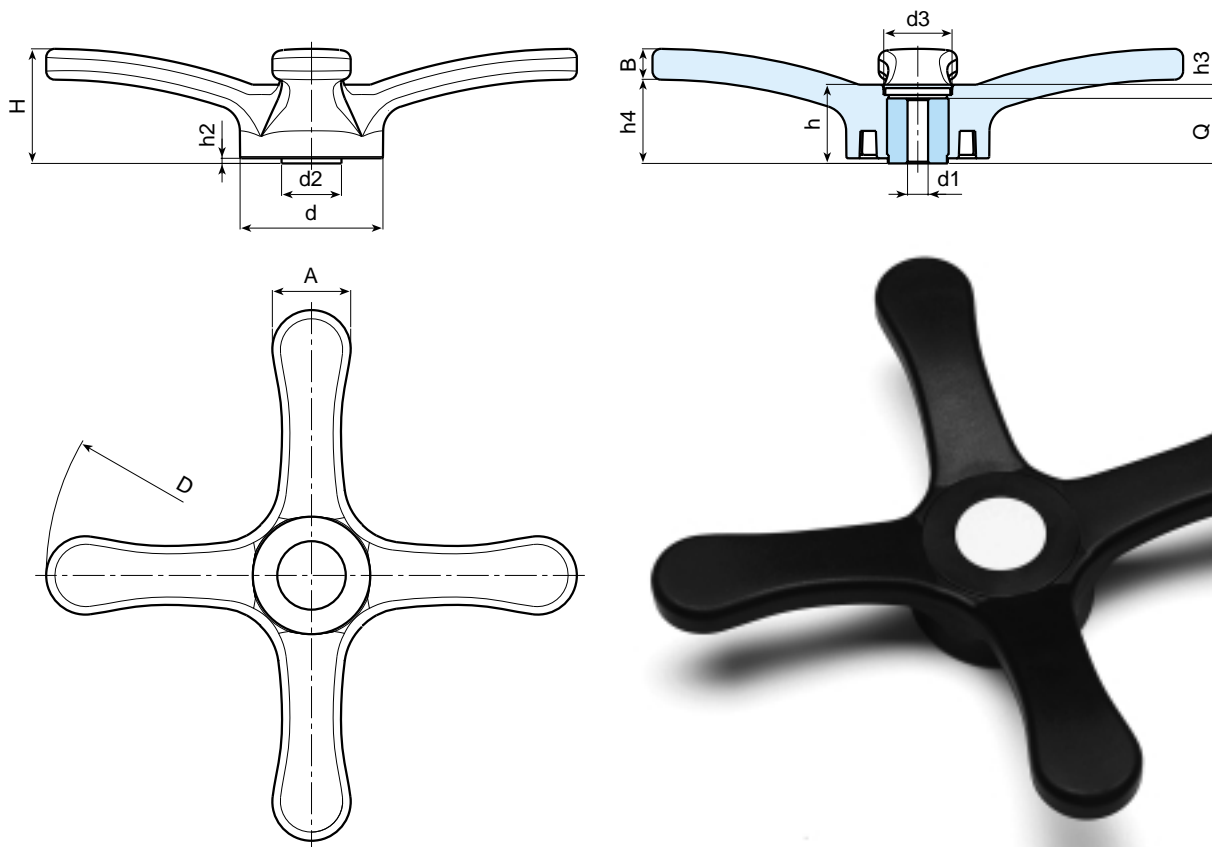

Art.	D	H	h	d	d2	A	B	h2	h3	h4	d3	d1 H7	Q	dm	Weight (gr)
D454-310 D05	308	66	45,5	83	35,5	45,5	20	3	7,5	46	34	5 H9	38	26	900
D454-310 D18	308	66	45,5	83	35,5	45,5	20	3	7,5	46	34	18	38	26	890

It's possible to increase the hole, by boring, until **dm**.

The range will shortly be extended with additional diameters.