

# ART. E215

## CRANK HANDLE WITH THREADED INSERT AND REVOLVING HANDLE

**MATERIAL:**

Reinforced polyamide.  
Oils and greases resistant.

**SURFACE:**

Satin.

**COLOUR:**

Black (RAL 9011).

**MAIN INSERT:**

Brass blind threaded bush.  
(\* ) Zinc plated steel blind threaded bush.

**SIDE INSERT:**

Brass right through threaded bush.

**SIDE HANDLE:**

Revolving handle Art. M144  
(see chapter M on page 206).



**SPECIAL REQUESTS:**

- It is possible to supply the inserts in different materials, on request and for quantities.
- It is possible to supply arm and handle with colours as shown in the table at page 22, on request and for quantities.

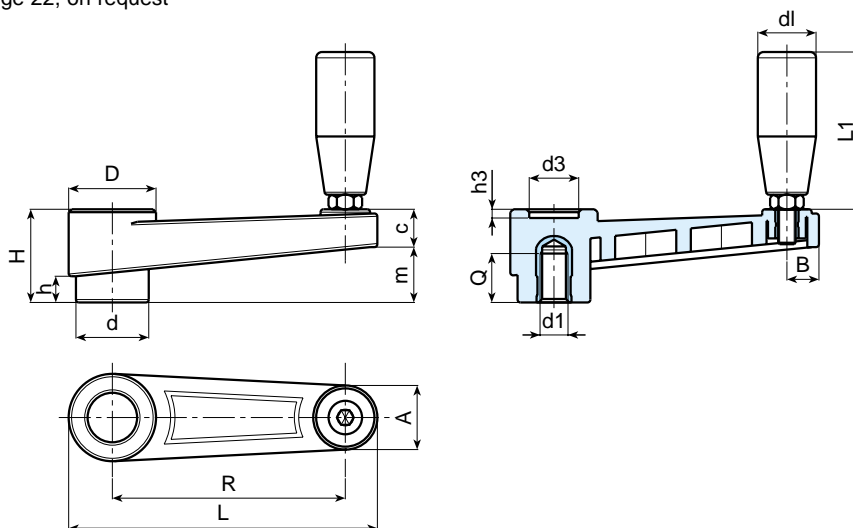

Art.	L	R	H	D	d	m	c	A	B	h	d3	h3	d1	Q	dl	L1	Weight (gr)
E215-65 M08	88	65	30	26	22	17	13	18	9,5	8	15	3	M08	15	20	56	67
E215-65 M10	88	65	30	26	22	17	13	18	9,5	8	15	3	M10	15	20	56	70
E215-65 M12	88	65	30	26	22	17	13	18	9,5	8	15	3	M12	18	20	56	73
E215-80 M08	106	80	33	30	26	20	13	21,5	11	9	17	3	M08	18	20	56	83
E215-80 M10	106	80	33	30	26	20	13	21,5	11	9	17	3	M10	18	20	56	87
E215-80 M12	106	80	33	30	26	20	13	21,5	11	9	17	3	M12	18	20	56	90
E215-110 M10	138	110	39	33	28,5	22	14	22	12	11	21	3,5	M10	14	21	65	135
E215-110 M12	138	110	39	33	28,5	22	14	22	12	11	21	3,5	M12	18	21	65	137
E215-110 M14	138	110	39	33	28,5	22	14	22	12	11	21	3,5	M14	18	21	65	140
E215-140 M12	173	140	49	43	35	34	16	25,5	13,5	15	27	3	M12	19	23	76	238
E215-140 M14	173	140	49	43	35	34	16	25,5	13,5	15	27	3	M14	18	23	76	223
E215-140 M16	173	140	49	43	35	34	16	25,5	13,5	15	27	3	(* ) M16	18	23	76	251
E215-185 M12	219	180	54	46	39	40	16,5	26,5	14	16,5	27,5	4	M12	17	25	86	312
E215-185 M14	219	180	54	46	39	40	16,5	26,5	14	16,5	27,5	4	M14	19	25	86	320
E215-185 M16	219	180	54	46	39	40	16,5	26,5	14	16,5	27,5	4	(* ) M16	18	25	86	331