

# ART. E216

## CRANK HANDLE WITH SMOOTH INSERT AND REVOLVING HANDLE

**MATERIAL:**

Reinforced polyamide.  
Oils and greases resistant.

**SURFACE:**

Satin.

**COLOUR:**

Black (RAL 9011).

**MAIN INSERT:**

Zinc plated steel blind bored bush with H7 tolerance.

**SIDE INSERT:**

Brass right through threaded bush.

**SIDE HANDLE:**

Revolving handle Art. M144 (see chapter M on page 206).



**SPECIAL REQUESTS:**

- It is possible to supply the inserts with d1 diameter by customer design, on request and for quantities.
- It is possible to supply the inserts with different treatment-finishes, on request and for quantities.
- It is possible to supply the inserts in different materials, on request and for quantities.
- It is possible to supply arm and handle with colours as shown in the table at page 22, on request and for quantities.

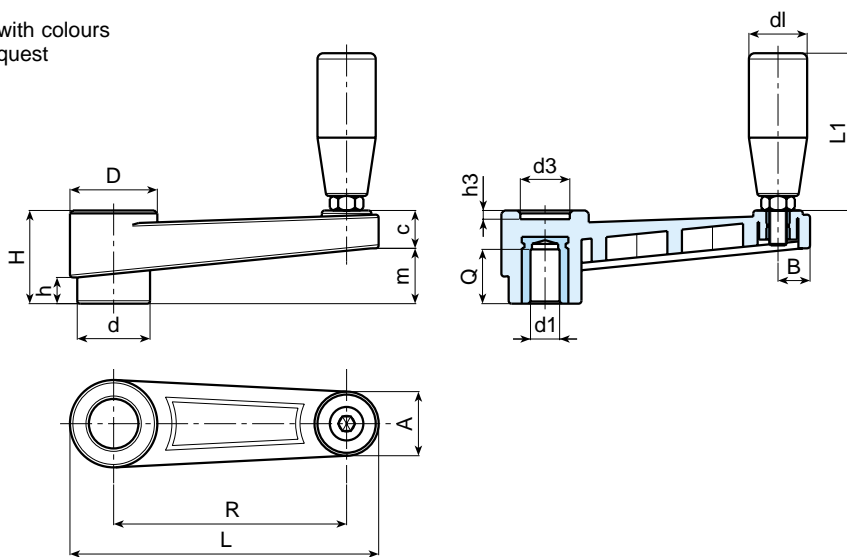

Art.	L	R	H	D	d	m	c	A	B	h	d3	h3	dm	d1 H7	Q	dl	L1	Weight (gr)
E216-65 D05	88	65	30	26	22	17	13	18	9,5	8	15	3	12	D05 H9	20	20	56	96
E216-65 D10	88	65	30	26	22	17	13	18	9,5	8	15	3	12	D10	20	20	56	92
E216-80 D05	106	80	33	30	26	19	13	21,5	11	9	17	3	14	D05 H9	20	20	56	110
E216-80 D10	106	80	33	30	26	19	13	21,5	11	9	17	3	14	D10	20	20	56	105
E216-110 D05	138	110	39	33	28,5	22	14	22	12	11	21	3,5	14	D05 H9	22	21	66	160
E216-110 D12	138	110	39	33	28,5	22	14	22	12	11	21	3,5	14	D12	22	21	66	152
E216-140 D05	173	140	49	43	35	34	16	25,5	13,5	15	27	3	20	D05 H9	22	23	76	250
E216-140 D14	173	140	49	43	35	34	16	25,5	13,5	15	27	3	20	D14	22	23	76	242
E216-185 D05	219	180	54	46	39	40	16,5	26,5	14	16,5	27,5	4	24	D05 H9	26	25	86	430
E216-185 D16	219	180	54	46	39	40	16,5	26,5	14	16,5	27,5	4	24	D16	26	25	86	385

It's possible to increase the hole, by boring, until **dm**.