

ART. F177

6-LOBE HANDWHEEL WITH THREADED THROUGH FEMALE INSERT

MATERIAL:

Reinforced polyamide.
Oils and greases resistant.

SURFACE:

Satin.

COLOUR:

Black (RAL 9011).

MAIN INSERT:

Brass right through threaded bush.



SPECIAL REQUESTS:

- It is possible to supply the inserts in different materials, on request and for quantities.
- It is possible to supply colours as shown in the table at page 22, on request and for quantities.

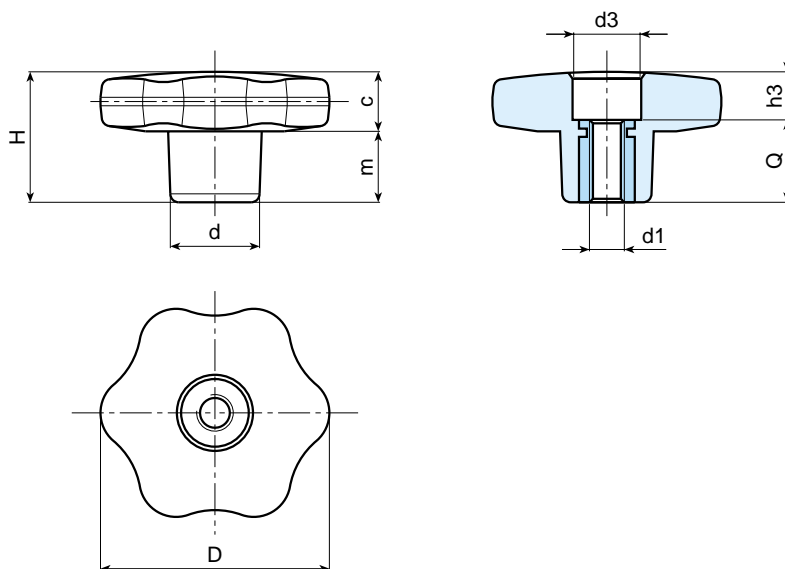

Art.	D	H	d	c	m	d3	h3	Q	d1	Weight (gr)
F177-30 M05	30	22	15	11	11	11	4	18	M5	12
F177-30 M06	30	22	15	11	11	11	4	18	M6	13
F177-30 M08	30	22	15	11	11	11	4	18	M8	13
F177-30 M10	30	22	15	11	11	11	4	18	M10	14
F177-40 M06	40	24,5	17	12	12,5	12	6	18	M6	20
F177-40 M08	40	24,5	17	12	12,5	12	6	18	M8	21
F177-40 M10	40	24,5	17	12	12,5	12	6	18	M10	22
F177-50 M06	50	29	20	14	15	14	11	18	M6	33
F177-50 M08	50	29	20	14	15	14	11	18	M8	34
F177-50 M10	50	29	20	14	15	14	11	18	M10	35
F177-50 M12	50	29	20	14	15	14	11	18	M12	35
F177-60 M08	60	34	24	16	18	15	16	18	M8	54
F177-60 M10	60	34	24	16	18	15	16	18	M10	55
F177-60 M12	60	34	24	16	18	15	16	18	M12	55
F177-60 M14	60	34	24	16	18	15	16	18	M14	56