

ART. G735

4-LOBE HANDWHEEL WITH ELONGATED HUB AND THREADED STUD

MATERIAL:

Reinforced polyamide.
Oils and greases resistant.

SURFACE:

Satin.

COLOUR:

Black (RAL 9011).

MAIN INSERT:

Zinc plated steel threaded stud.



SPECIAL REQUESTS:

- It is possible to supply the inserts with different lengths, on request and for quantities.
- It is possible to supply the inserts with different threads, on request and for quantities.
- It is possible to supply the inserts in different materials, on request and for quantities.
- It is possible to supply the handwheels with hubs to drawing, on request and for quantities.

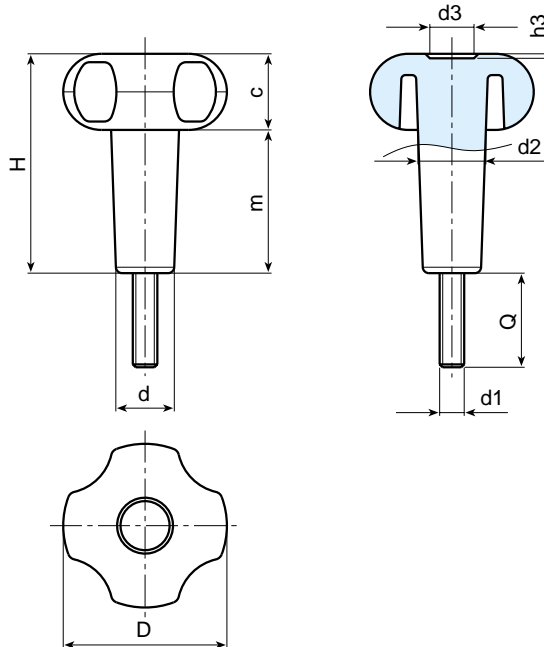

Art.	D	H	m	d	c	d2	d3	h3	d1	Q	Weight (gr)
G735-30 T35 M06	30	47	33,5	13,5	14	15	12	2	M06	15	23
G735-30 T35 M08	30	47	33,5	13,5	14	15	12	2	M08	30	36
G735-40 T35 M08	41	54	35	16,5	19	17	12	3	M08	20-30-40	47-49-53
G735-40 T35 M10	41	54	35	16,5	19	17	12	3	M10	15	54
G735-50 T40 M08	52	61	39	17,5	22	19	14	2,5	M08	15-20-30	64-67-69
G735-50 T40 M10	52	61	39	17,5	22	19	14	2,5	M10	15-20-30-40	74-77-79-82
G735-50 T50 M08	52	71	49	18	22	20,5	14	2,5	M08	30	75
G735-50 T60 M08	52	80	58	18	22	21	14	2,5	M08	30	86
G735-60 T60 M08	59	83	58	23	25	24	24	4	M08	20	115
G735-60 T60 M10	59	83	58	23	25	24	24	4	M10	30-40	130-138
G735-60 T80 M10	59	103	78	23	25	24	24	4	M10	50	150

LOCKING HANDWHEELS