

ART. P902

FLOOR-ANCHOR MOUNTING FOOT

MATERIAL:

Reinforced polyamide.
Oils and greases resistant.

SURFACE:

Satin.

COLOUR:

Black (RAL 9011).

INSERT:

Zinc plated steel articulated, threaded stem.
For stem lengths longer than the standard the insert does not have a hexagonal seat; in this case, a seat is milled into the threading (see fig. 2).

ANCHORING TO THE FLOOR:

The holes in the foot used for anchoring the mount to the floor, are supplied closed. To open them simply break the plastic membrane (see drawing).

SPECIAL REQUESTS:

- It is possible to supply the inserts with different lengths, on request and for quantities.
- It is possible to supply colours as shown in the table at page 22, on request and for quantities.

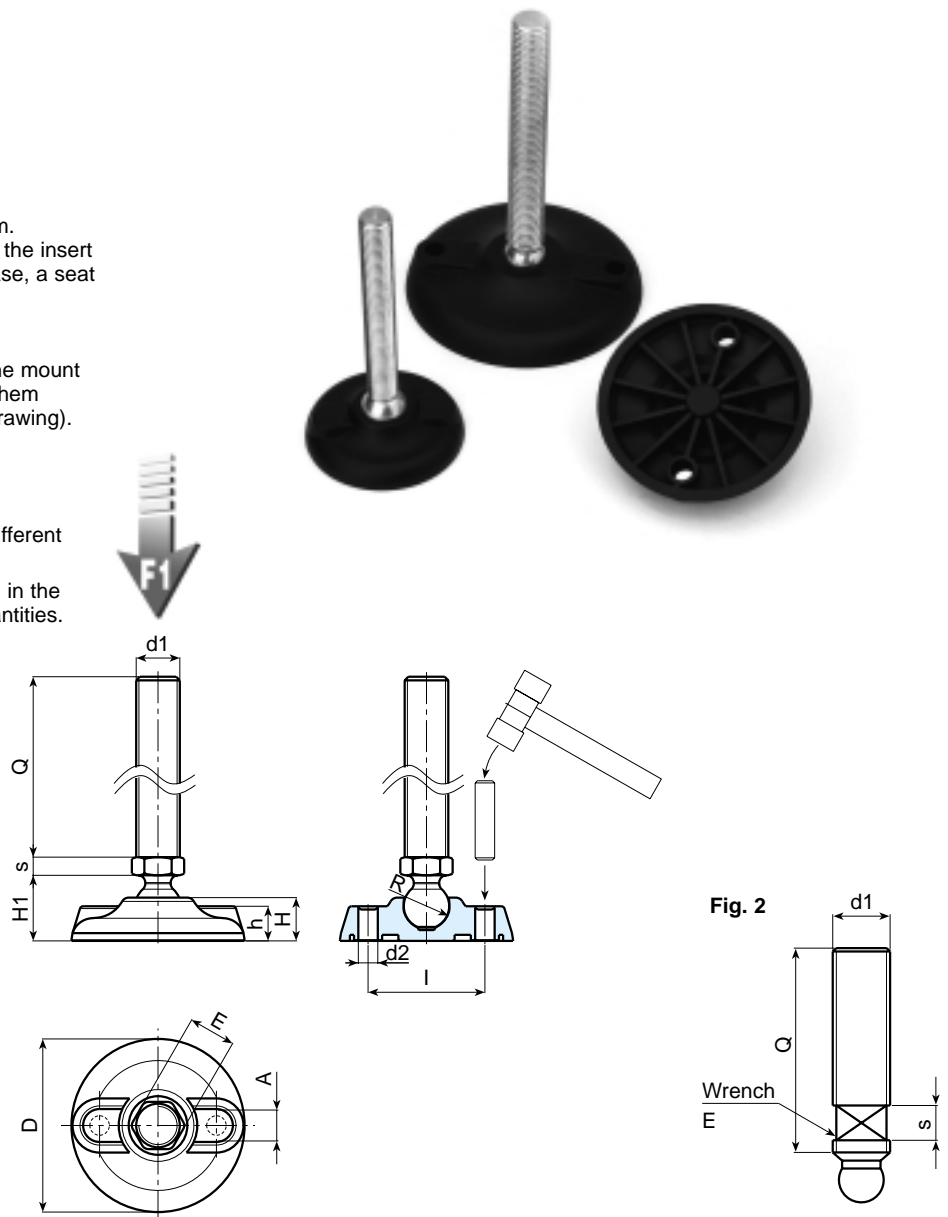

Art.	D	H	I	H1	h	A	E	s	R	d2	d1	Q	Weight (gr)	F1 (N)
P902-80 M10	80	20	54	25,5	16	20	13	5	12,5	9	M10	45-70-100	74-86-123	10000
P902-80 M12	80	20	54	25,5	16	20	13	5	12,5	9	M12	45-70-100	84-101-145	10000
P902-80 M14	80	20	54	26	16	20	17	6,5	15	9	M14	50-70-90-100	142-166-190-202	13000
P902-80 M16	80	20	54	26	16	20	17	6,5	15	9	M16	50-70-90-110-130	160-193-225-256-288	13000
P902-105 M12	105	22	74	28	18,5	21	17	6,5	15	11	M12	50-90-110	171-206-225	15000
P902-105 M14	105	22	74	28	18,5	21	17	6,5	15	11	M14	50-70-90-100	187-211-235-247	15000
P902-105 M16	105	22	74	28	18,5	21	17	6,5	15	11	M16	50-70-90-110-130	206-238-270-301-333	15000
P902-105 M20	105	22	74	28	18,5	21	16 (*)	7	15	11	M20 (*)	70-110	290-370	15000
P902-130 M12	130	24	99	30	20	21	17	6,5	15	13	M12	50-90-130	235-271-307	17000
P902-130 M14	130	24	99	30	20	21	17	6,5	15	13	M14	50-70-90-100	252-276-300-312	17000
P902-130 M16	130	24	99	30	20	21	17	6,5	15	13	M16	50-70-90-110-130	271-303-335-366-398	17000
P902-130 M20	130	24	99	30	20	21	16 (*)	7	15	13	M20 (*)	70-110	350-430	17000

(*) Seat for the wrench obtained by milling (fig. 2)