

ART. R809

BAR STOP

MATERIAL:

Reinforced polyamide.
Oils and greases resistant.

SURFACE:

Satin.

COLOUR:

Black (RAL 9011).

HOLE :

Smooth right through hole obtained by moulding the plastic.

MAIN INSERT:

(1) Zinc plated steel nut DIN 934/UNI 5588.

LOCKING HANDWHEEL:

R809-130: art. G732-30 M6x25.

R809-158: art. G732-40 M6x30.



SPECIAL REQUESTS:

- None.

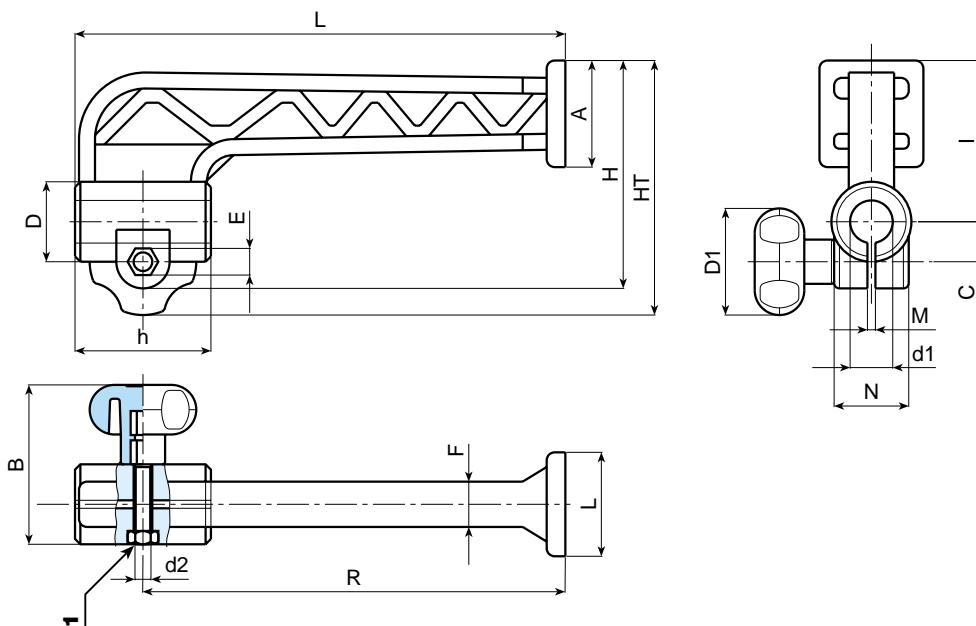

Art.	R	L	H	HT	D	D1	A	B	C	E	F	G	I	M	N	h	d1	d2	Weight (gr)
R809-130 D12	132	150	85	90	25	30	25	46	12	10	14	24	63	2,5	23	37	12	M6	72
R809-130 D13	132	150	85	90	25	30	25	46	12	10	14	24	63	2,5	23	37	13	M6	70
R809-130 D16	132	150	85	90	25	30	25	46	12	10	14	24	63	2,5	23	37	16	M6	67
R809-158 D16	158	185	95	105	29	40	39	57	15	10	17	38	70	2,5	27	50	16	M6	130
R809-158 D20	158	185	95	105	29	40	39	57	15	10	17	38	70	2,5	27	50	16	M6	123