

ART. W298

ALUMINIUM CONTROL WHEEL WITH SMOOTH HOLE AND REVOLVING, FOLDING HANDLE

MATERIAL:

Die cast aluminium.

SURFACE:

Satin finish surface, except for the low roughness turned areas (T).

COLOUR:

H - Nickel-plated (surface treatment).

V - Painted black (RAL 9011).

A - Natural grey anodization.

To be specified with the order.

CENTRE CAP:

H - Nickel plated: black ABS cap (Ral 9011).

V - Painted black: grey ABS cap (Ral 7035).

A - Anodization: grey ABS cap (Ral 7035).

SIDE HANDLE:

Revolving handle and folding Art. M136 (see chapter M on page 210).

HOLE:

Smooth through hole, remachined with tolerance class of H7.

For fixing systems please refer to the technical notes attached to the catalogue.

SPECIAL REQUESTS:

- It is possible to supply the handwheels with customised hole d1, on request and for quantities.

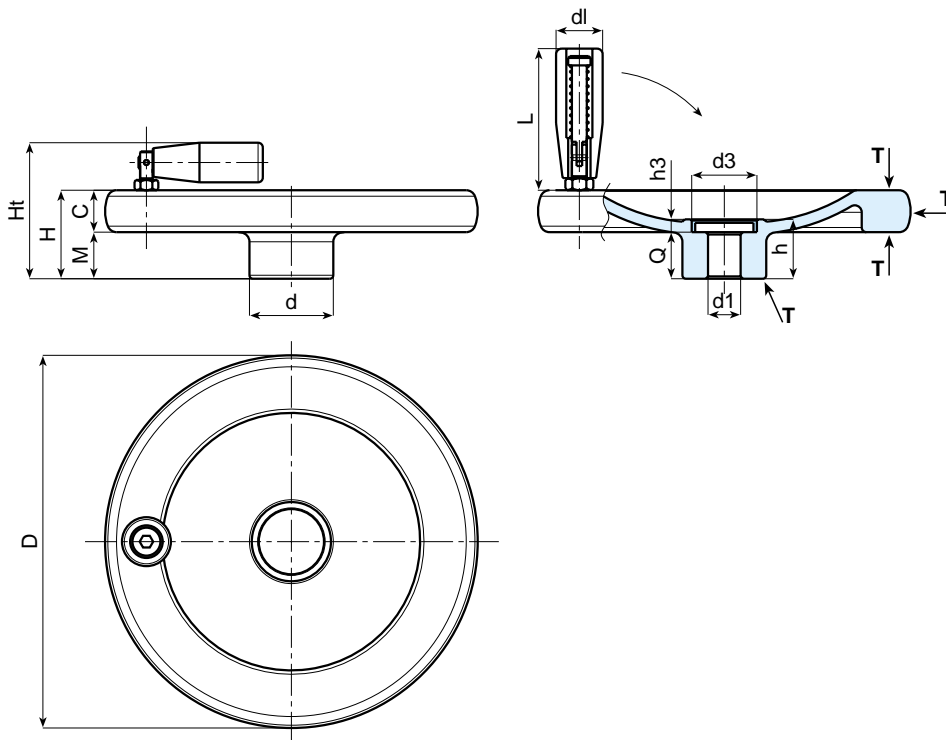

Ver. H

Art.	d	D	H	Ht	m	c	h	h3	d3	d1 H7	Q	dl	L	Weight (g)
W298-80 D08 "HVA"	26	80	26	50	14	12	21	5,5	20	D08	15,5	20	56	
W298-100 D10 "HVA"	28	100	28	52	14	14	21,5	5,5	20	D10	16	20	56	
W298-130 D12 "HVA"	36	130	35	65	19	16	25,5	5,5	28	D12	20	25	76	
W298-160 D14 "HVA"	36	160	38	68	20	18	25,5	5,5	28	D12	20	25	76	
W298-200 D16 "HVA"	42	200	44	79	24	20	31,5	6	34	D16	25,5	26	89	