

T559



PC

UL94
HB



CIRCULAR SAW GUARD WITH KNIFE ENGRAVER PROLONG

Material:

(1-2-9) Polycarbonate.

Surface:

Satin.

Colour:

Transparent.

SPECIAL REQUESTS:

- Suction tube adapter D. 40 Art. T556040.T01.

Inserts:

- (3) Aluminium rivet AL 4010 d.4.0x10.
- (4) Brass threaded through insert.
- (5) Galvanised steel washer.
- (6) Spring pin d.6x30 in black-oxide treated highyield steel DIN 148.
- (7) Self-tapping brass screw M3x10 in ottone DIN 97.
- (8) Brass turned threaded stud used for prolong fixing and rotation.
- (9) Knife engraver mobile prolong.

Locking lever:

Clamping lever art. A523065.TM08x30.

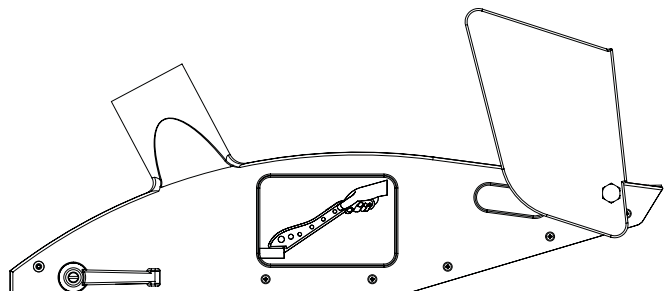
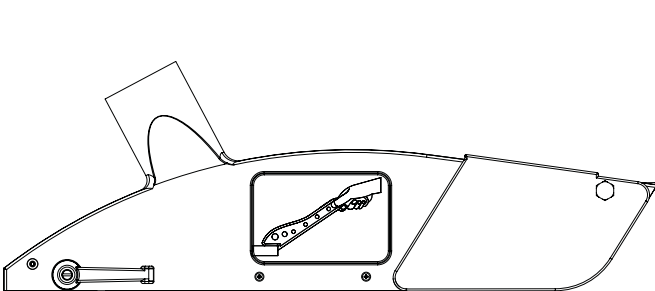

Prolongs in the lowest position.

Prolongs in the highest position.

Art.	L	A	B	H	D	d	d1	l	l1	l2	l3	l4	l5	l6	h1	h2	h3	h4	h5	h6
T559300.CCRI	490	30	60	172	60	53	6	145	297	176	17	21,5	47,5	70	105	79,5	52	14,5	20	11,5
	a°	a1°	a2°	a3°	a4°	a5°	b	b1	f	m	n	o	r	r1	s	x	x1	W	K	g
	16,5	41	152	152	7,5	22	56	21	3	4	7	8	430	10	4	130	170	192	13	650

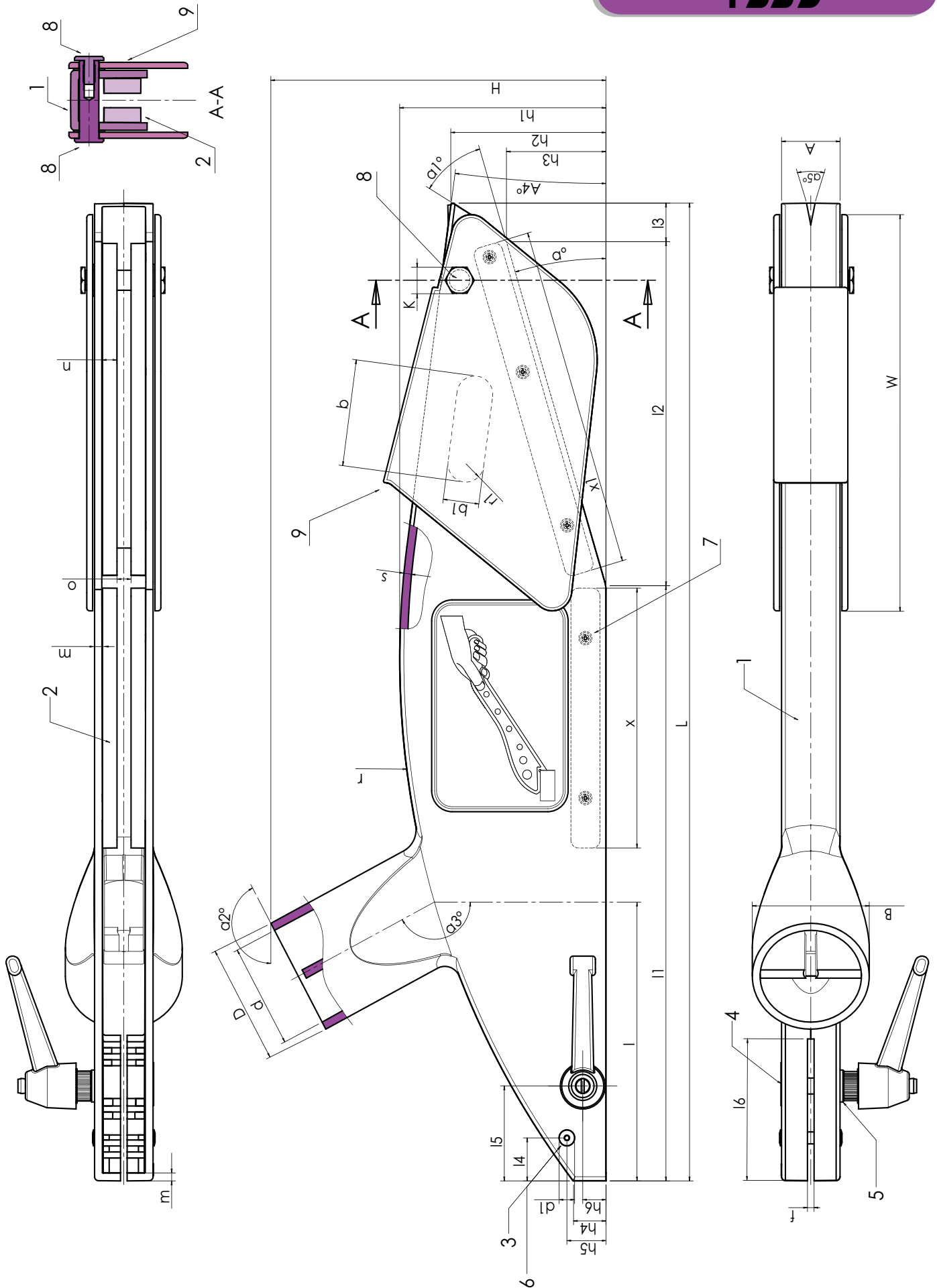

Presumable presence in the stock in %

(☒) 90% (☑) 40% (⊖) 5% (⊕)